



CLASSIC SERIES A3S4-C

15 PSI STEAM / 30, 40, 75 PSI WATER • 83-88% EFFICIENCY • 4 Sq Ft FIRESIDE HEATING SURFACE/BHP
 OPTIONAL INTEGRAL FINNED COIL HEAT EXCHANGER FOR INDIRECT LOADS
 HIGH EFFICIENCY • HEAVY DUTY CONSTRUCTION • THREE PASS SCOTCH BOX DESIGN • ASME SECTION IV

BOILER RATINGS & DIMENSIONS

MODEL: A3S4-C	10	15	20	25	30	40	50	60	70	80	90	105	110	120	125	135	150	175	200	225	250
Gas Input (MBH)	399	600	800	1,000	1,200	1,610	2,010	2,410	2,820	3,220	3,620	4,240	4,430	4,865	5,040	5,450	6,050	7,100	8,100	9,100	10,100
Oil Input (GPH)	2.9	4.3	5.7	7.1	8.6	11.5	14.4	17.2	20.1	23.0	25.9	30.3	31.6	34.8	36.0	38.9	43.2	50.7	57.9	65.0	72.1
Output (MBH)	330	500	670	835	1,000	1,340	1,675	2,010	2,345	2,680	3,015	3,520	3,680	4,040	4,184	4,520	5,020	5,860	6,695	7,532	8,369
Output (Horsepower)	10	15	20	25	30	40	50	60	70	80	90	105	110	120	125	135	150	175	200	225	250
Htg Surf. FS (Sq Ft)	48	60	87	102	125	162	200	242	285	325	359	425	458	480	508	542	602	710	834	908	1001
Furnace Vol (Cu Ft)	4.5	4.5	6.1	6.1	7.7	9.3	13.6	15.8	20.3	20.3	23.2	26.0	28.1	30.2	30.2	38.0	43.3	56.0	66.3	72.0	77.6
Water Cap. (Gal, NWL)	91	98	128	122	152	176	226	260	310	297	343	378	396	446	442	468	530	648	745	790	838
Dry Weight (LBS)	1,925	1,950	2,250	2,350	2,700	3,025	3,750	4,200	4,900	5,050	5,450	5,950	6,100	6,550	6,700	6,850	7,750	9,400	11,350	12,900	14,750
A Width	28	28	28	28	28	28	**35¼	**35¼	**35¼	**35¼	**35¼	**35¼	**35¼	**35¼	**35¼	42	42	42	42	42	42
B Width With Trim	40	40	40	40	40	40	46	46	46	46	46	46	46	46	46	54	54	54	54	54	54
C Length of Skid	29¼	29¼	39	39	48¼	58¼	58½	68¼	68¼	68¼	78	87¼	92¼	96½	102	78	94	111½	131	143½	156
D Overall Length	64	64	76	76	86	96	112	121	123	128	138	154	156	158	162	142	152	181	200	212	225
E Supply Height	70	70	70	70	70	70	78	78	84	84	84	84	84	84	84	96	96	96	96	96	96
F Height With Trim	78	78	78	78	78	78	85	85	92	92	92	92	92	92	92	102	102	102	102	102	102
G Stack Dia., O.D.	6	6	8	8	8	8	10	10	12	12	12	12	12	12	12	16	18	20	20	20	20
H Stack Height	50	50	50	50	50	50	54	54	61	61	61	61	61	61	61	75	75	75	75	75	75
I Burner Port Height	18	18	18	18	18	18	19½	19½	19½	19½	19½	19½	19½	19½	19½	23¼	23¼	23¼	23¼	23¼	23¼
J Supply Size (*Flg)	3	3	3	3	*4	*4	*6	*6	*6	*6	*6	*8	*8	*8	*8	*8	*10	*10	*10	*10	*10
K Supply Location	14¼	14¼	19½	19½	24¼	29	29	34	34	34	39	44	46	48	51	39	44	56	65½	72	78
L Return Size (NPT)	2	2	2	3	3	3	4	4	4	4	4	4	4	4	4	4	4	4	4	4	4
M Return Height	8½	8½	8½	8½	8½	8½	10½	10½	10½	10½	10½	10½	10½	10½	10½	10½	10½	10½	10½	10½	10½
N BD/Drain Size	1½	1½	1½	1½	1½	1½	1½	1½	1½	1½	1½	1½	1½	1½	1½	1½	1½	1½	1½	1½	1½
O Tube Pull Space	30	30	40	40	50	60	60	69	69	69	79	89	93	98	103	79	89	113	132	144	157
P Indirect Coil Height	52	52	52	52	52	52	56½	56½	62½	62½	62½	62½	62½	62½	62½	76	76	76	76	76	76

**WIDTH LISTED AT 35¼" (THIS INCLUDES THE ANGLE TRIM FOR SECURING OUTER BOILER JACKET). WIDTH WITH ANGLE TRIM REMOVED IS 34".

ALL DIMENSIONS ARE IN INCHES. DIMENSIONS SUBJECT TO CHANGE WITHOUT NOTICE. CERTIFIED DRAWING AVAILABLE UPON REQUEST. LARGER RETURN SIZE CONNECTIONS ARE AVAILABLE FOR WATER APPLICATIONS. CONSULT FACTORY FOR AVAILABLE INDIRECT COIL CONFIGURATIONS, CAPACITIES AND MATERIALS.

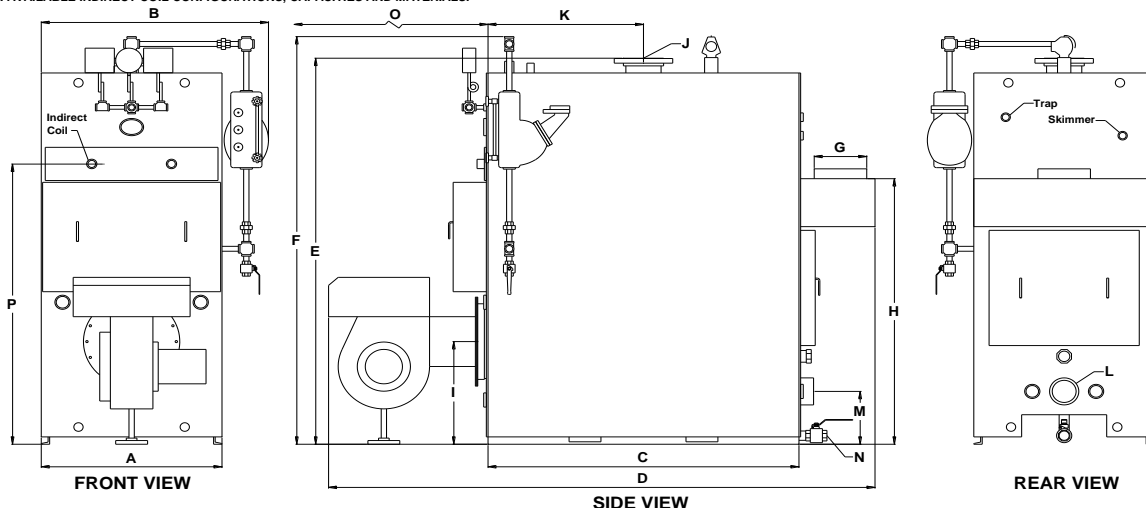

QUALITY • PERFORMANCE • EFFICIENCY • EXPERIENCE

“QUALITY PRODUCTS BY LOCAL CRAFTSMEN” STEEL BOILERS & WATER HEATERS SINCE 1936

ALDRICH COMPANY • 341 EAST WILLIAMS ST., P.O. Box 97, WYOMING, IL 61491 • TEL: 309-695-2311 • FAX: 309-695-5779

WWW.ALDRICHCO.COM